

North American Electric, Inc.

"Your Source for a Complete Line of Electric Motors"

STAINLESS STEEL WASHDOWN DUTY MOTORS

- **1/3 – 20 Horse Power**
- **3600, 1800 and 1200 RPM**
- **Stainless Steel / Washdown Duty**
- **Inverter Duty**



**SPECIFICALLY DESIGNED FOR FOOD PROCESSING
PHARMACEUTICAL AND OTHER ENVIRONMENTS REQUIRING
EXTREME CLEANLINESS AND FREQUENT WASHDOWNS.**



ISO 9001

Mission Statement

To provide the United States market for industrial motors and controls with products which meet or exceed customer expectations for quality, performance, and reliability at the lowest possible cost and delivered in accordance with the customer's schedule, through our authorized distributor network.

Company History

North American Electric, Inc. is a wholesale supplier of Special Purpose and General Purpose, AC electric motors and controls. We take pride in supplying high performance, high quality products at extremely competitive prices throughout the United States. Donald E. Hackman, Sr. and David E. Hackman founded the company in October of 1993. The company's primary focus is sourcing quality electric motors from various manufacturers, both locally and internationally, and distributing them throughout the United States through local distributors and service centers. Our nationwide distributor and service network offer strong local support for our products by providing critical logistical, technical and maintenance support as well as fast, friendly customer service.

WARRANTY POLICY

All motors sold by North American Electric, Inc. are warranted to be free from defects in material and workmanship. The warranty is 24 months from the date of manufacture but no less than 18 months from date of invoice. Also, all motors installed within 24 months from date of manufacture will be warranted for no less than 12 months from the date the motor is installed. North American Electric, Inc. shall, at its option and expense, either repair or replace any such motor or part, which is defective within the warranty period. To be covered under warranty, any motor must have at all times been operated or used under normal operating conditions for which the motor was designed.

In the event of warranty claims, North American Electric, Inc. must be notified promptly following any motor failure. The motor should be sent to a North American Electric, Inc. authorized service center to diagnose the cause of failure. After this examination, a determination will be made if the failure was due to defective material and/or workmanship. If the failure was due to defective material and/or workmanship, North American Electric, Inc. will replace or repair the motor.

North American Electric's liability under this warranty or any other warranty whether expressed or implied in law or fact shall be limited to the repair or replacement of defective material and workmanship, and in no event shall North American Electric, Inc. be liable for consequential or indirect damages, including freight.

YOUR SOURCE FOR A COMPLETE LINE OF ELECTRIC MOTORS !!!

	<p><u>SINGLE PHASE, 56C FRAME, TEFC</u> 1/3-2 HP 2,4 POLE HIGH STARTING TORQUES MANUAL OVERLOAD PROTECTION (OPTIONAL) CAPACITOR START / CAPACITOR RUN DESIGN ROLLED STEEL FRAME CONSTRUCTION IP55 PROTECTION-REMOVABLE FEET</p>		<p><u>NEMA PREMIUM EFFICIENCY INVERTER DUTY MOTORS</u> MEETS OR EXCEEDS NEMA PREMIUM EFFICIENCY LEVELS QUALIFIES FOR ENERGY EFFICIENCY REBATES</p>
	<p><u>SINGLE PHASE, FARM DUTY, TEFC</u> 1/3-10 HP 4 POLE HIGH STARTING TORQUES MANUAL OVERLOAD PROTECTION (1/3 THRU 5 HP) CAPACITOR START / CAPACITOR RUN DESIGN ROLLED STEEL FRAMES CAST IRON ENDBELLS</p>		<p><u>PREMIUM CRUSHER DESIGN MOTORS</u> 1-500 HP 4,6,8 POLE NEMA DESIGN C HIGH STRENGTH 4140 GRADE STAINLESS STEEL SHAFT 586/7U FRAME HEAVY DUTY CAST IRON CONSTRUCTION (INCLUDING FAN COVER) BEARING SIZES: DE=NU324 ODE=6324</p>
	<p><u>SINGLE PHASE OPEN DRIPPROOF</u> 3,5 HP 4 POLE HIGH STARTING TORQUES CAPACITOR START / CAPACITOR RUN DESIGN ROLLED STEEL FRAME CONSTRUCTION CAST IRON ENDBELLS</p>		<p><u>PREMIUM EFFICIENCY EXPLOSION PROOF MOTORS</u> 1-300 HP 2,4,6 POLE ALL MOTORS MEET OR EXCEED UL 674 SPECIFICATION AS REQUIRED BY OSHA FOR INSTALLATION AND USE IN HAZARDOUS LOCATIONS. CLASS I, DIVISION I, GROUPS C&D AND CLASS II, DIVISION I, GROUPS E,F AND G UL CERTIFIED - FILE E228654 CSA + "C" + "US" - CANADIAN STANDARD ISO9001</p>
	<p><u>THREE PHASE, 56C FRAME, TEFC</u> 1/3-3 HP 2,4 POLE HIGH EFFICIENCY DESIGN GENERAL PURPOSE MOTORS ROLLED STEEL FRAME CONSTRUCTION, ALUMINUM ENDBELLS IP55 PROTECTION REMOVABLE FEET</p>		<p><u>OIL WELL PUMP MOTORS, TEFC</u> 3-150 HP 6 POLE NEMA DESIGN D HIGH SLIP(5% TO 8% SLIP) SPECIAL PURPOSE OIL WELL PUMP MOTORS HEAVY DUTY CAST IRON FRAME CONSTRUCTION</p>
	<p><u>THREE PHASE, TEFC ROLLED STEEL MOTORS</u> PREMIUM EFFICIENCY DESIGN-GENERAL PURPOSE, LIGHT WEIGHT ROLLED STEEL FRAME</p>		<p><u>PREMIUM EFFICIENCY ALUMINUM MOTORS</u> 1-10 HP 2,4 POLE HIGH EFFICIENCY DESIGN GENERAL PURPOSE, THREE PHASE, TEFC MOTORS LIGHT WEIGHT ALUMINUM FRAME</p>
	<p><u>THREE PHASE OPEN DRIPPROOF</u> 1-15 HP 2,4 POLE PREMIUM EFFICIENCY DESIGN GENERAL PURPOSE MOTORS ROLLED STEEL FRAME CONSTRUCTION, CAST IRON ENDBELLS</p>		<p><u>VERTICAL HOLLOW SHAFT PUMP MOTORS</u> 10 HP - 250 HP, 4 POLE HIGH TORQUE - HIGH THRUST</p>
	<p><u>STAINLESS STEEL WASHDOWN DUTY MOTORS</u> 1/3 HP - 20HP 2,4,6 POLE IP 67 PROTECTION INVERTER DUTY</p>		<p><u>ELECTRIC MOTOR CONTROL</u> FULL VOLTAGE STARTERS SOFT STARTS INVERTERS PUMP PACKAGES</p>
			<p><u>MOTOR SLIDE BASES</u> AVAILABLE 56C THRU 505U</p>

STAINLESS STEEL / WASHDOWN DUTY MOTORS

"Buy on Value Not on Price"

- 1/3 – 20 Horse Power
- 3600, 1800 and 1200 RPM
- Stainless Steel / Washdown Duty
- Inverter Duty



AC Inverter Duty - 20:1 Variable Torque; 10:1 Constant Torque

EISA Compliant High Efficiency Design

NEMA Design B

Stainless Steel Construction

Double Sealed Bearings on Both Ends

IP67 Protection as Standard

C-Flange as Standard

Totally Enclosed Fan Cooled

Class F Insulation System with Class H VPI Epoxy Resin Protection

Double Punched Foot Design

**Certifications:
UL Listed
CSA+C+US
CE
ISO 9001**

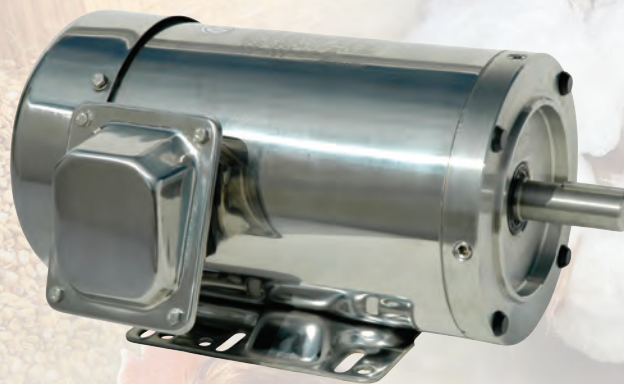

APPLICATIONS:

Specifically Designed for Food Processing, Pharmaceutical and Other Environments Requiring Extreme Cleanliness and Frequent Washdowns. Applications include Washdown Applications, Food Processing, Chemical Processing, Pharmaceuticals, Poultry Processing, Meat Processing, Dairy Applications, Bakeries, Snack Foods, Bottling and Extremely Corrosive Environments.

STAINLESS STEEL / WASHDOWN DUTY LIST PRICES

HP	RPM	FRAME	VOLTS	CATALOG NUMBER	LIST PRICE C-FACE FOOTED	LIST PRICE C-FACE FOOTLESS (RB)
1/3	1800	56C	208-230/460	SS56C1/3M-4 (RB)	\$555	\$538
1/2	3600	56C	208-230/460	SS56C1/2M-2 (RB)	\$565	\$548
	1800	56C	208-230/460	SS56C1/2M-4 (RB)	\$575	\$558
	1200	56C	208-230/460	SS56C1/2M-6 (RB)	\$600	\$582
3/4	3600	56C	208-230/460	SS56C3/4M-2 (RB)	\$579	\$562
	1800	56C	208-230/460	SS56C3/4M-4 (RB)	\$615	\$597
	1200	56C	208-230/460	SS56C3/4M-6 (RB)	\$650	\$631
	1200	143TC	208-230/460	SS143TC3/4M-6 (RB)	\$650	\$631
1	3600	56C	208-230/460	SS56C1M-2 (RB)	\$609	\$591
	1800	56C	208-230/460	SS56C1M-4 (RB)	\$625	\$606
	1800	143TC	208-230/460	SS143TC1M-4 (RB)	\$675	\$655
	1200	145TC	208-230/460	SS145TC1M-6 (RB)	\$725	\$703
1.5	3600	56C	208-230/460	SS56C1.5M-2 (RB)	\$689	\$668
	3600	143TC	208-230/460	SS143TC1.5M-2 (RB)	\$659	\$639
	1800	56C	208-230/460	SS56C1.5M-4 (RB)	\$699	\$678
	1800	145TC	208-230/460	SS145TC1.5M-4 (RB)	\$675	\$655
	1200	182TC	208-230/460	SS182TC1.5M-6 (RB)	\$1,300	\$1,261
2	3600	56C	208-230/460	SS56C2M-2 (RB)	\$735	\$713
	3600	145TC	208-230/460	SS145TC2M-2 (RB)	\$699	\$678
	1800	56C	208-230/460	SS56C2M-4 (RB)	\$739	\$717
	1800	145TC	208-230/460	SS145TC2M-4 (RB)	\$765	\$742
	1200	184TC	208-230/460	SS184TC2M-6 (RB)	\$1,400	\$1,358
3	3600	182TC	208-230/460	SS182TC3M-2 (RB)	\$1,650	\$1,601
	1800	182TC	208-230/460	SS182TC3M-4 (RB)	\$1,600	\$1,552
	1200	213TC	208-230/460	SS213TC3M-6 (RB)	\$2,200	\$2,134
5	3600	184TC	208-230/460	SS184TC5M-2 (RB)	\$1,785	\$1,731
	1800	184TC	208-230/460	SS184TC5M-4 (RB)	\$1,850	\$1,795
	1200	215TC	208-230/460	SS215TC5M-6 (RB)	\$2,575	\$2,498
7.5	3600	213TC	208-230/460	SS213TC7.5M-2 (RB)	\$2,750	\$2,668
	1800	213TC	208-230/460	SS213TC7.5M-4 (RB)	\$2,700	\$2,619
	1200	254TC	208-230/460	SS254TC7.5M-6 (RB)	\$4,800	\$4,656
10	3600	215TC	208-230/460	SS215TC10M-2 (RB)	\$2,900	\$2,813
	1800	215TC	208-230/460	SS215TC10M-4 (RB)	\$2,950	\$2,862
	1200	256TC	208-230/460	SS256TC10M-6 (RB)	\$5,100	\$5,093
15	3600	254TC	208-230/460	SS254TC15M-2 (RB)	\$6,200	\$6,014
	1800	254TC	208-230/460	SS254TC15M-4 (RB)	\$6,200	\$6,014
20	3600	256TC	208-230/460	SS256TC20M-2 (RB)	\$6,800	\$6,596
	1800	256TC	208-230/460	SS256TC20M-4 (RB)	\$6,800	\$6,596

NOTE:

Add (RB) to the end of the model number to indicate Round Body or C-Face Footless.

STAINLESS STEEL / WASHDOWN DUTY MOTORS PERFORMANCE DATA

HP	RPM	Frame	Service Factor	DE Bearing	ODE Bearing	Full Load AMPS @ 460V	FLT Ft-Lb	LRT %	BDT %	Full Load (%) Efficiency	Full Load (%) Power Factor	Weight
1/3	3600	56C	1.15	6205ZZ	6205ZZ	0.55	0.5	2.5	3	74	0.85	27
1/2	3600	56C	1.15	6205ZZ	6205ZZ	0.75	0.75	2.8	3.2	77	0.88	29
1/2	1800	56C	1.15	6205ZZ	6205ZZ	0.80	1.5	2.9	3.7	82.5	0.78	29
1/2	1200	56C	1.15	6205ZZ	6205ZZ	0.90	2.2	2.6	3.4	80	0.63	30
3/4	3600	56C	1.15	6205ZZ	6205ZZ	1.10	1.1	2.4	3	80	0.90	36
3/4	1800	56C	1.15	6205ZZ	6205ZZ	1.10	2.2	3.3	4.6	82.5	0.78	32
3/4	1200	56C	1.15	6205ZZ	6205ZZ	1.85	3.3	3.3	3.7	80	0.65	49
3/4	1200	143TC	1.15	6205ZZ	6205ZZ	1.82	3.3	3.3	3.7	80	0.65	49
1	3600	56C	1.15	6205ZZ	6205ZZ	1.40	1.5	3	3.7	80	0.90	36
1	1800	56C	1.15	6205ZZ	6205ZZ	1.45	3	3.4	4.2	82.5	0.78	37
1	1800	143TC	1.15	6205ZZ	6205ZZ	1.45	3	3.4	4.2	82.5	0.78	37
1	1200	145TC	1.15	6205ZZ	6205ZZ	2.00	4.4	2.8	3.6	80	0.68	60
1.5	3600	56C	1.15	6205ZZ	6205ZZ	2.00	2.3	2.6	3.2	84	0.91	41
1.5	3600	143TC	1.15	6205ZZ	6205ZZ	2.00	2.3	2.6	3.2	84	0.91	41
1.5	1800	56C	1.15	6205ZZ	6205ZZ	2.00	4.4	3.8	4.3	84	0.83	43
1.5	1800	145TC	1.15	6205ZZ	6205ZZ	2.00	4.4	3.8	4.3	84	0.83	43
1.5	1200	182TC	1.15	6308ZZ	6306ZZ	2.45	6.6	2.5	2.7	85.5	0.70	79
2	3480	56C	1.15	6205ZZ	6205ZZ	2.40	2.9	3.1	3.3	84	0.91	49
2	3480	145TC	1.15	6205ZZ	6205ZZ	2.40	2.9	3.1	3.3	84	0.91	49
2	1750	56C	1.15	6205ZZ	6205ZZ	3.00	5.9	3.3	4	84	0.83	52
2	1750	145TC	1.15	6205ZZ	6205ZZ	3.00	5.9	3.3	4	84	0.83	52
2	1175	184TC	1.15	6308ZZ	6306ZZ	3.10	8.8	2.4	2.5	85.5	0.71	95
3	3510	182TC	1.15	6308ZZ	6306ZZ	4.05	4.4	2.1	2.6	86.5	0.89	77
3	1765	182TC	1.15	6308ZZ	6306ZZ	4.00	8.8	2.3	3	89.5	0.81	78
3	1175	213TC	1.15	6308ZZ	6208ZZ	4.30	13.2	2.1	2.8	87.5	0.74	160
5	3525	184TC	1.15	6308ZZ	6306ZZ	6.10	7.3	2.1	2.5	88.5	0.91	95
5	1765	184TC	1.15	6308ZZ	6306ZZ	6.25	14.7	2.4	2.5	89.5	0.86	99
5	1175	215TC	1.15	6308ZZ	6208ZZ	6.80	22	2.1	2.6	87.5	0.78	197
7.5	3520	213TC	1.15	6308ZZ	6208ZZ	9.50	11.1	2	2.6	89.5	0.85	151
7.5	1755	213TC	1.15	6308ZZ	6208ZZ	9.30	22	2.2	3	91.7	0.83	179
7.5	1175	254TC	1.15	6309ZZ	6309ZZ	10.30	33.7	2.5	2.20	89.5	77.0	253
10	3525	215TC	1.15	6308ZZ	6208ZZ	12.20	14.7	2.1	2.7	90.2	0.87	166
10	1760	215TC	1.15	6308ZZ	6208ZZ	12.20	29.3	2.1	3	91.7	0.85	210
10	1175	256TC	1.15	6309ZZ	6309ZZ	13.40	44.9	2.20	2.00	89.5	79.0	286
15	3540	254TC	1.15	6309ZZ	6309ZZ	18.50	21.9	2	2.6	91	0.90	253
15	1765	254TC	1.15	6309ZZ	6309ZZ	18.50	43.8	2	2.5	92.4	0.88	286
20	3540	256TC	1.15	6309ZZ	6309ZZ	23.00	29.1	2	2.5	91	0.90	286
20	1765	256TC	1.15	6309ZZ	6309ZZ	24.50	58.3	2	2.5	93	0.88	352

STAINLESS STEEL / WASHDOWN DUTY MOTOR DIMENSIONS

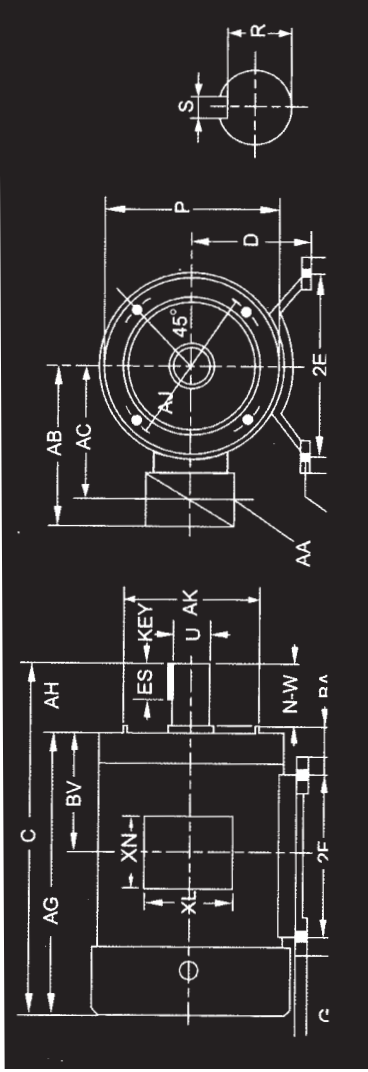

HP	RPM	Frame	Frame Mounting				Conduit Box				Motor Dimensions						Shaft Extension Key Seat						
			E	2F	H	BA	AA	AB	AC	XL	XN	A	B	C	D	G	P	N-W	U	R	S	ES	
1/3	1800	56C	2.44	3	1.22 x 0.34	2.75	0.86	5.75	4.25	4.72	3.8	6.5	6.5	11.6	3.5	0.118	6.5	1.88	0.625	0.517	0.19	1.41	
	3600	56C	2.44	3	1.22 x 0.34	2.75	0.86	5.75	4.25	4.72	3.8	6.5	6.5	11.6	3.5	0.118	6.5	1.88	0.625	0.517	0.19	1.41	
1/2	1800	56C	2.44	3	1.22 x 0.34	2.75	0.86	5.75	4.25	4.72	3.8	6.5	6.5	11.6	3.5	0.118	6.5	1.88	0.625	0.517	0.19	1.41	
	1200	56C	2.44	3	1.22 x 0.34	2.75	0.86	5.75	4.25	4.72	3.8	6.5	6.5	12.6	3.5	0.118	6.5	1.88	0.625	0.517	0.19	1.41	
3/4	3600	56C	2.44	3	1.22 x 0.34	2.75	0.86	5.75	4.25	4.72	3.8	6.5	6.5	12.6	3.5	0.118	6.5	1.88	0.625	0.517	0.19	1.41	
	1800	56C	2.44	3	1.22 x 0.34	2.75	0.86	5.75	4.25	4.72	3.8	6.5	6.5	12.6	3.5	0.118	6.5	1.88	0.625	0.517	0.19	1.41	
1	1200	56C	2.44	3	1.22 x 0.34	2.75	0.86	5.75	4.25	4.72	3.8	6.5	6.5	12.6	3.5	0.118	6.5	1.88	0.625	0.517	0.19	1.41	
	1200	143TC	2.75	4	1.22 x 0.34	2.75	0.86	5.75	4.25	4.72	3.8	6.5	6.5	12.7	3.5	0.118	6.5	2.25	0.875	0.771	0.19	1.41	
1	3600	56C	2.44	3	1.22 x 0.34	2.75	0.86	5.75	4.25	4.72	3.8	6.5	6.5	12.6	3.5	0.118	6.5	1.88	0.625	0.517	0.19	1.41	
	1800	56C	2.44	3	1.22 x 0.34	2.75	0.86	5.75	4.25	4.72	3.8	6.5	6.5	12.6	3.5	0.118	6.5	1.88	0.625	0.517	0.19	1.41	
1	1800	143TC	2.75	4	1.22 x 0.34	2.75	0.86	5.75	4.25	4.72	3.8	6.5	6.5	13.9	3.5	0.118	6.5	2.25	0.875	0.771	0.19	1.41	
	1200	145TC	2.75	4	1.22 x 0.34	2.75	0.86	5.75	4.25	4.72	3.8	6.5	6.5	12.7	3.5	0.118	6.5	2.25	0.875	0.771	0.19	1.41	
1.5	3600	56C	2.44	3	1.22 x 0.34	2.75	0.86	5.75	4.25	4.72	3.8	6.5	6.5	12.6	3.5	0.118	6.5	1.88	0.625	0.517	0.19	1.41	
	3600	143TC	2.44	3	1.22 x 0.34	2.75	0.86	5.75	4.25	4.72	3.8	6.5	6.5	12.7	3.5	0.118	6.5	2.25	0.875	0.771	0.19	1.41	
1.5	1800	56C	2.44	3	1.22 x 0.34	2.75	0.86	5.75	4.25	4.72	3.8	6.5	6.5	12.6	3.5	0.118	6.5	1.88	0.625	0.517	0.19	1.41	
	1800	145TC	2.75	4	1.22 x 0.34	2.75	0.86	5.75	4.25	4.72	3.8	6.5	6.5	12.7	3.5	0.118	6.5	2.25	0.875	0.771	0.19	1.41	
2	1200	182TC	3.75	4.5	0.71 x 0.47	3.5	0.94	7	5.3	4.45	4.05	8.8	8.8	15.3	4.5	0.118	6.5	2.75	1.125	0.986	0.19	1.78	
	3600	56C	2.44	3	1.22 x 0.34	2.75	0.86	5.75	4.25	4.72	3.8	6.5	6.5	13.8	3.5	0.118	6.5	1.88	0.625	0.517	0.19	1.41	
2	3600	145TC	2.44	3	1.22 x 0.34	2.75	0.86	5.75	4.25	4.72	3.8	6.5	6.5	13.9	3.5	0.118	6.5	2.25	0.875	0.771	0.19	1.41	
	1800	56C	2.44	3	1.22 x 0.34	2.75	0.86	5.75	4.25	4.72	3.8	6.5	6.5	13.8	3.5	0.118	6.5	1.88	0.625	0.517	0.19	1.41	
2	1800	145TC	2.75	4	1.22 x 0.34	2.75	0.86	5.75	4.25	4.72	3.8	6.5	6.5	13.9	3.5	0.118	6.5	2.25	0.875	0.771	0.19	1.41	
	1200	182TC	3.75	4.5	0.71 x 0.47	3.5	0.94	7	5.3	4.45	4.05	8.8	8.8	16.0	4.5	0.118	6.5	2.75	1.125	0.986	0.19	1.78	
3	3600	182TC	3.75	4.5	0.71 x 0.47	3.5	0.94	7	5.3	4.45	4.05	8.8	8.8	15.3	4.5	0.118	6.5	2.75	1.125	0.986	0.19	1.78	
	1800	182TC	3.75	4.5	0.71 x 0.47	3.5	0.94	7	5.3	4.45	4.05	8.8	8.8	15.3	4.5	0.118	6.5	2.75	1.125	0.986	0.19	1.78	
3	1800	182TC	3.75	4.5	0.71 x 0.47	3.5	0.94	7	5.3	4.45	4.05	8.8	8.8	15.3	4.5	0.118	6.5	2.75	1.125	0.986	0.19	1.78	
	1200	213TC	4.25	5.5	0.71 x 0.47	4.25	0.94	7.6	6.2	4.45	4.05	10	10	19.0	5.25	0.157	10	3.38	1.375	1.201	0.312	2.41	
5	3600	184TC	3.75	4.5	0.71 x 0.47	3.5	0.94	7	5.3	4.45	4.05	8.8	8.8	16.0	4.5	0.118	6.5	2.75	1.125	0.986	0.25	1.78	
	1800	184TC	3.75	4.5	0.71 x 0.47	3.5	0.94	7	5.3	4.45	4.05	8.8	8.8	16.0	4.5	0.118	6.5	2.75	1.125	0.986	0.25	1.78	
7.5	1200	215TC	4.25	5.5	0.71 x 0.47	4.25	0.94	7.6	6.2	4.45	4.05	10	10	22.5	5.25	0.157	10	3.38	1.375	1.201	0.312	2.41	
	3600	213TC	4.25	5.5	0.71 x 0.47	4.25	0.94	7.6	6.2	4.45	4.05	10	10	19.0	5.25	0.157	10	3.38	1.375	1.201	0.312	2.41	
10	1800	213TC	4.25	5.5	0.71 x 0.47	4.25	0.94	7.6	6.2	4.45	4.05	10	10	19.0	5.25	0.157	10	3.38	1.375	1.201	0.312	2.41	
	1200	254TC	5	8.25	0.53	4.75	1	9	7.8	7	7	12	12	23.4	6.25	0.5	12.7	4	1.625	1.416	0.375	2.91	
10	3600	215TC	4.25	5.5	0.71 x 0.47	4.25	0.94	7.6	6.2	4.45	4.05	10	10	22.5	5.25	0.157	10	3.38	1.375	1.201	0.312	2.41	
	1800	215TC	4.25	5.5	0.71 x 0.47	4.25	0.94	7.6	6.2	4.45	4.05	10	10	22.5	5.25	0.157	10	3.38	1.375	1.201	0.312	2.41	
15	1200	256TC	5	10	0.53	4.75	1	9	7.8	7	7	12	12	11.25	25.1	6.25	0.5	12.7	4	1.625	1.416	0.375	2.91
	3600	254TC	5	8.25	0.53	4.75	1	9	7.8	7	7	12	12	9.5	23.4	6.25	0.5	12.7	4	1.625	1.416	0.375	2.91
20	3600	256TC	5	10	0.53	4.75	1	9	7.8	7	7	12	12	11.25	25.1	6.25	0.5	12.7	4	1.625	1.416	0.375	2.91
	1800	256TC	5	10	0.53	4.75	1	9	7.8	7	7	12	12	11.25	25.1	6.25	0.5	12.7	4	1.625	1.416	0.375	2.91

Toll Free: 800-884-0404 • www.naemotors.com • e-mail: sales@naemotors.com

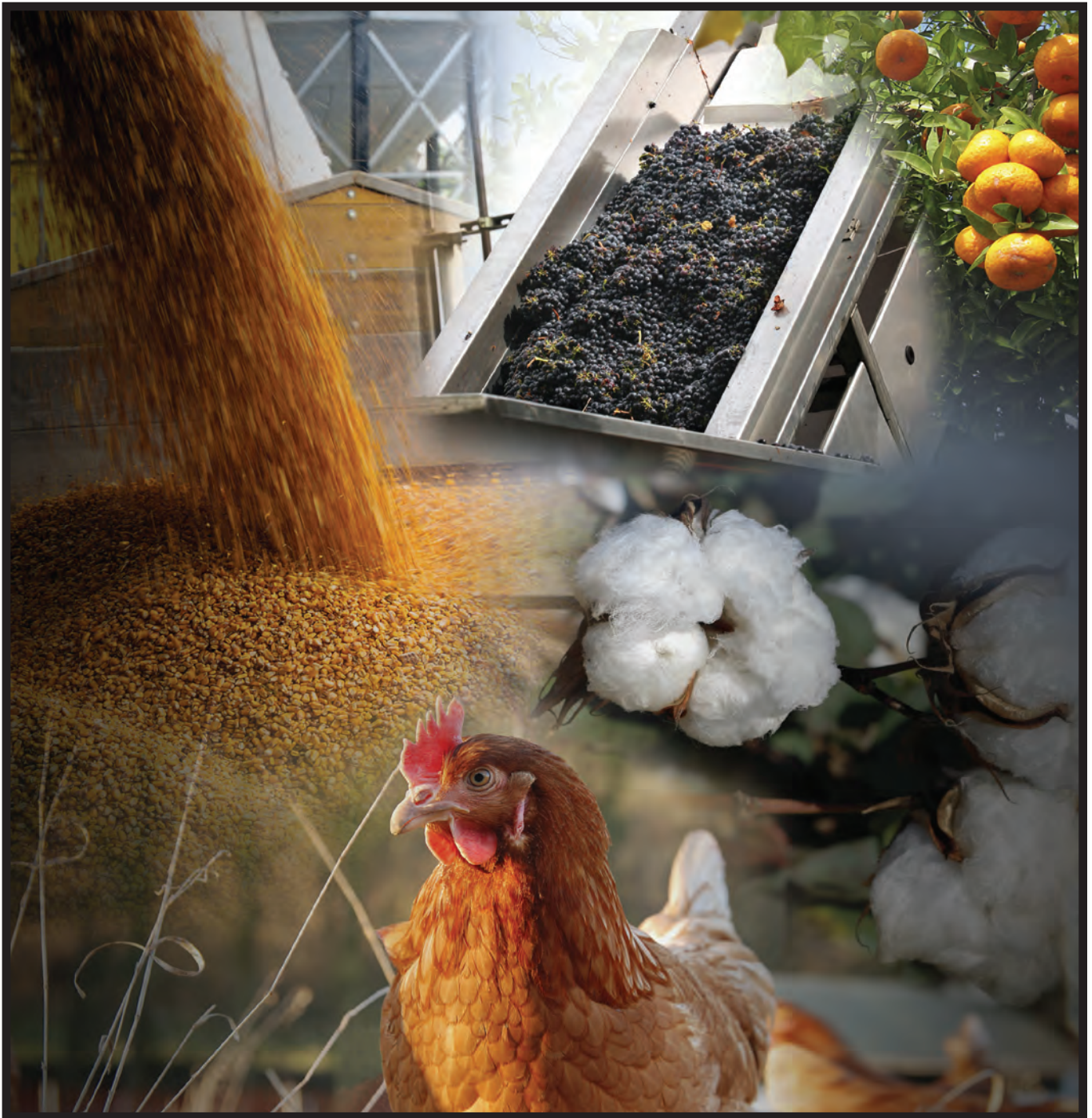

Data subject to change without notice

Distributed by:

North American Electric, Inc. • P.O. Drawer 130 • 350 Vaiden Drive • Hernando, MS 38632
Toll Free: 800-884-0404 • Phone: 662-429-8049 • Fax: 662-429-8546 • Sales: 800-884-0405
www.naemotors.com • e-mail: sales@naemotors.com

